



Cam Units CHD
Schieber CHD
Unità a Camme CHD



MCR[®]
STANDARD DIE COMPONENTS



AERIAL CAM UNIT - OBEN HÄNGENDER SCHIEBER - UNITÀ A CAMME SOSPESA

OMCR CODE	Work Angle	Slider Width (mm)	Closed Cam Height (mm)	Work Area W x H (mm)	Max Work Force with shoulder 10 ⁶ cycles (kN)	Extraction Force (kN)		Page number
	β					E _F		
						F _s	Spring	
CHD050	0°÷65° (5° steps)	50	180	50x65	60	1,14÷1,31	1,44÷1,72	688
CHD065	0°÷65° (5° steps)	65	180	65x65	60	1,14÷1,31	1,44÷1,72	692
CHD080	0°÷65° (5° steps)	80	275	80x88	149	1,13÷1,37	1,50÷1,85	696
CHD100	0°÷65° (5° steps)	100	275	100x88	149	1,13÷1,37	1,50÷1,85	700
CHD150	0°÷65° (5° steps)	150	355	150x120	391	2,29	7,15	704
CHD180	0°÷65° (5° steps)	180	355	180x120	396	2,29	7,15	708
CHD200	0°÷65° (5° steps)	200	355	200x120	396	2,29	7,15	712
CHD250	0°÷65° (5° steps)	250	355	250x160	645	4,58	14,30	716
CHD300	0°÷65° (5° steps)	300	355	300x160	645	4,58	14,30	720

Cam Units CHD



High stock availability



AERIAL CAM UNIT - OBEN HÄNGENDER SCHIEBER - UNITÀ A CAMME SOSPESA

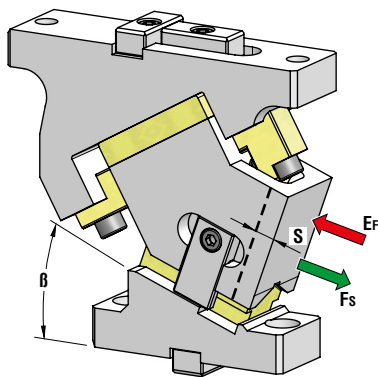

OMCR CODE	Work Angle β	Stroke (mm) S	Max Work Force with shoulder (kN) Fs	Extraction Force (kN) Ef	
				Spring	Gas Spring
CHD050.00	0°	14,98	60	1,31	1,72
CHD050.05	5°	15,62	60	1,30	1,67
CHD050.10	10°	15,64	60	1,14	1,60
CHD050.15	15°	16,96	60	1,14	1,60
CHD050.20	20°	18,43	60	1,14	1,60
CHD050.25	25°	18	60	1,29	1,53
CHD050.30	30°	17,36	60	1,17	1,47
CHD050.35	35°	18,87	60	1,17	1,47
CHD050.40	40°	20,57	60	1,17	1,47
CHD050.45	45°	22,54	60	1,17	1,47
CHD050.50	50°	23,34	60	1,17	1,44
CHD050.55	55°	26,05	60	1,17	1,44
CHD050.60	60°	31,51	60	1,17	1,47
CHD050.65	65°	36,57	60	1,17	1,47

OPTION CODE

SL	1 ÷ 60 (1mm steps)
----	--------------------

*Return Type: G = Gas Spring / S = Spring

				OPTION CODE
	Art.	Work Angle = 5°	Return Type*	SL
	CHD050	05	G	SL55

OMCR CODE	Work Angle β	Overall Dimensions (mm)			
		A	B	C	D
CHD050.00	0°	185	67,50	80	205
CHD050.05	5°	188,04	68,29	75	200
CHD050.10	10°	185,99	69,77	65	190
CHD050.15	15°	188,77	71,95	65	190
CHD050.20	20°	186,34	74,79	55	180
CHD050.25	25°	181,62	80,28	41	166
CHD050.30	30°	180,58	85,39	40	165
CHD050.35	35°	177,15	90,10	25	150
CHD050.40	40°	173,29	95,35	22,5	147,5
CHD050.45	45°	169,94	98,13	10	135
CHD050.50	50°	164,07	99,37	5	130
CHD050.55	55°	158,64	111,04	-15	110
CHD050.60	60°	152,61	118,08	-25	100
CHD050.65	65°	145,95	125,44	-35	90



AERIAL CAM UNIT - OBEN HÄNGENDER SCHIEBER - UNITÀ A CAMME SOSPESA

X VIEW

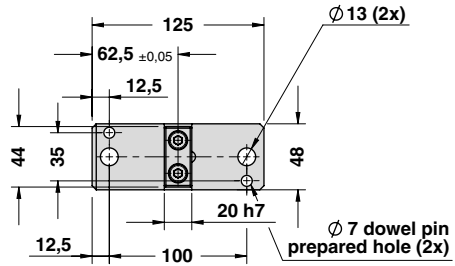
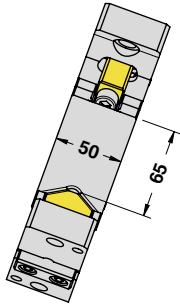

CAM DIAGRAM

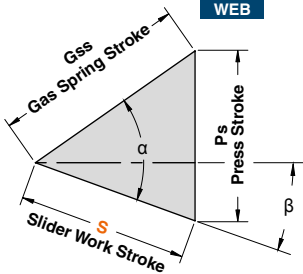

Work Angle	Inner Angle	Slider Work Stroke (mm)	Press Stroke (mm)	Gas Spring Stroke (mm)
β	α	S	Ps	Gss
0°	50°	14,98	17,85	23,3
5°	50°	15,62	16,92	22
10°	50°	15,64	15,64	20,1
15°	50°	16,96	15,86	20
20°	50°	18,43	16,30	20
25°	50°	18,00	15,21	18
30°	50°	17,36	14,15	16
35°	50°	18,87	14,96	16
40°	50°	20,57	16,00	16
45°	50°	22,54	17,33	16
50°	50°	23,34	17,88	15
55°	50°	26,05	20,03	15
60°	50°	31,51	24,51	16
65°	50°	36,57	29,00	16

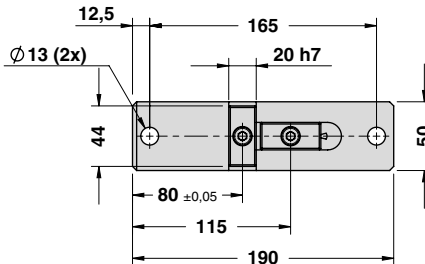
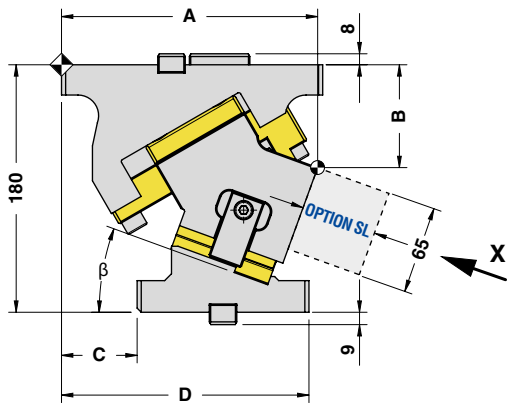



AERIAL CAM UNIT - OBEN HÄNGENDER SCHIEBER - UNITÀ A CAMME SOSPESA

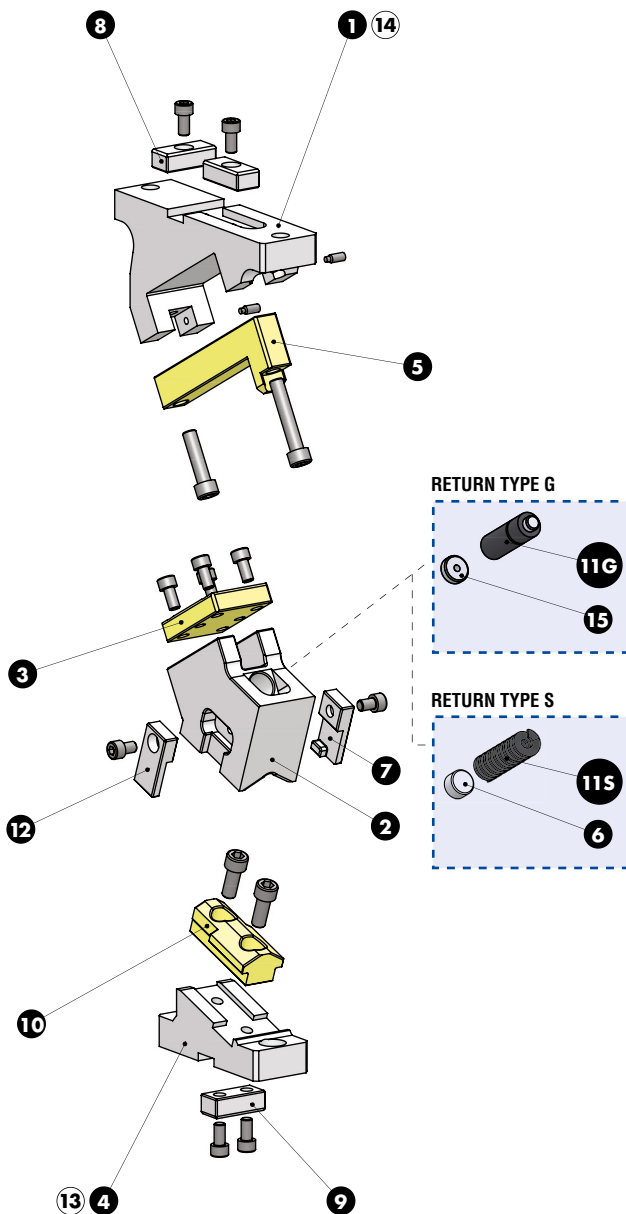



AERIAL CAM UNIT - OBEN HÄNGENDER SCHIEBER - UNITÀ A CAMME SOSPESA

SLIDER STRUCTURE, POSITIVE RETURN STRUCTURE AND CLEARANCES

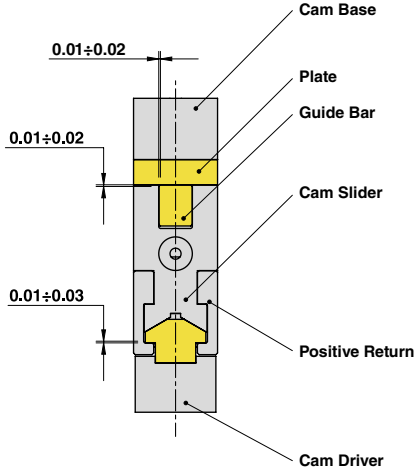

Cam Units CHD

PART LIST

Particular number	Description	Material	Quantity
1	Cam Base	CK45	1
2	Cam Slider	GG-30	1
3	Plate	CuZn25Al5 + Graphite - HB > 190	1
4	Cam Driver	CK45	1
5	Guide Bar	CuZn25Al5 + Graphite - HB > 190	1
6	Spring Spacer	CK45	1
7	Positive Return R	42CrMo4 Nitrided	1
8	Key	CK45	2
9	Key	CK45	1
10	Male "V" Driver	CuZn25Al5 + Graphite - HB > 190	1
11G	Gas Spring - Return Type G	-	1
11S	Spring - Return Type S	-	1
12	Positive Return L	42CrMo4 Nitrided	1
13	Cam Driver Fixing Screws M12x35 DIN 912	-	2
14	Cam Base Fixing Screws M12x45 DIN 912	-	2
15	Gas Spring Spacer	CK45	1



AERIAL CAM UNIT - OBEN HÄNGENDER SCHIEBER - UNITÀ A CAMME SOSPESA

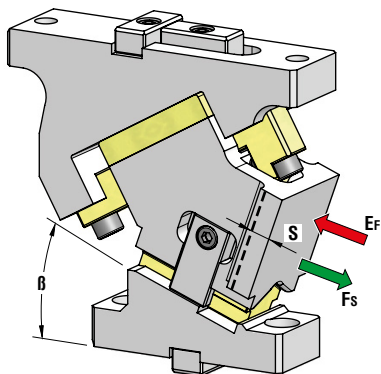

OMCR CODE	Work Angle	Stroke (mm)	Max Work Force with shoulder (kN)	Extraction Force (kN)	
	β			S	Fs
CHD065.00	0°	14,98	60	1,31	1,72
CHD065.05	5°	15,62	60	1,30	1,67
CHD065.10	10°	15,64	60	1,14	1,60
CHD065.15	15°	16,96	60	1,14	1,60
CHD065.20	20°	18,43	60	1,14	1,60
CHD065.25	25°	18	60	1,29	1,53
CHD065.30	30°	17,36	60	1,17	1,47
CHD065.35	35°	18,87	60	1,17	1,47
CHD065.40	40°	20,57	60	1,17	1,47
CHD065.45	45°	22,54	60	1,17	1,47
CHD065.50	50°	23,34	60	1,17	1,44
CHD065.55	55°	26,05	60	1,17	1,44
CHD065.60	60°	31,51	60	1,17	1,47
CHD065.65	65°	36,57	60	1,17	1,47

OPTION CODE

SL	1 ÷ 60 (1mm steps)
----	--------------------

*Return Type: G = Gas Spring / S = Spring



Art.	Work Angle = 5°	Return Type*	OPTION CODE
CHD065	05	G	SL55

OMCR CODE	Work Angle	Overall Dimensions (mm)			
		β	A	B	C
CHD065.00	0°	185	67,50	80	205
CHD065.05	5°	188,04	68,29	75	200
CHD065.10	10°	185,99	69,77	65	190
CHD065.15	15°	188,77	71,95	65	190
CHD065.20	20°	186,34	74,79	55	180
CHD065.25	25°	181,62	80,28	41	166
CHD065.30	30°	180,58	85,39	40	165
CHD065.35	35°	177,15	90,10	25	150
CHD065.40	40°	173,29	95,35	22,5	147,5
CHD065.45	45°	169,94	98,13	10	135
CHD065.50	50°	164,07	99,37	5	130
CHD065.55	55°	158,64	111,04	-15	110
CHD065.60	60°	152,61	118,08	-25	100
CHD065.65	65°	145,95	125,44	-35	90





AERIAL CAM UNIT - OBEN HÄNGENDER SCHIEBER - UNITÀ A CAMME SOSPESA

X VIEW

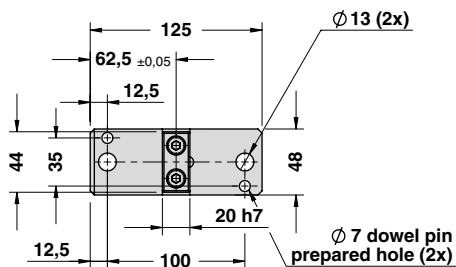
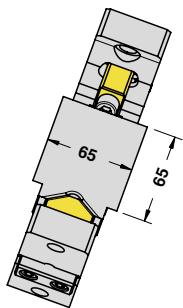

CAM DIAGRAM

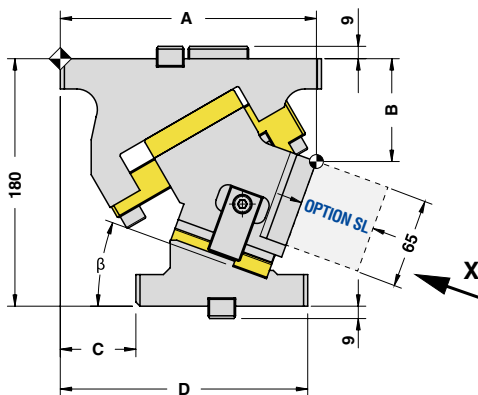
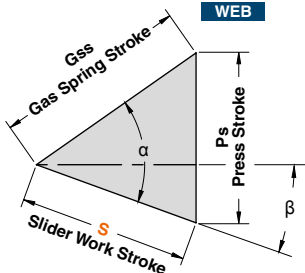

Work Angle	Inner Angle	Slider Work Stroke (mm)	Press Stroke (mm)	Gas Spring Stroke (mm)
β	α	S	Ps	Gss
0°	50°	14,98	17,85	23,3
5°	50°	15,62	16,92	22
10°	50°	15,64	15,64	20,1
15°	50°	16,96	15,86	20
20°	50°	18,43	16,30	20
25°	50°	18,00	15,21	18
30°	50°	17,36	14,15	16
35°	50°	18,87	14,96	16
40°	50°	20,57	16,00	16
45°	50°	22,54	17,33	16
50°	50°	23,34	17,88	15
55°	50°	26,05	20,03	15
60°	50°	31,51	24,51	16
65°	50°	36,57	29,00	16

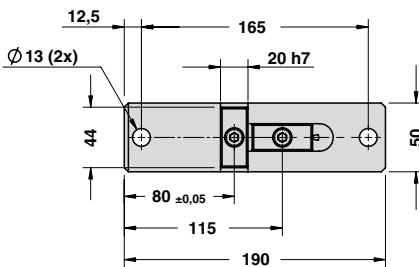

Cam Units CHD



AERIAL CAM UNIT - OBEN HÄNGENDER SCHIEBER - UNITÀ A CAMME SOSPESA

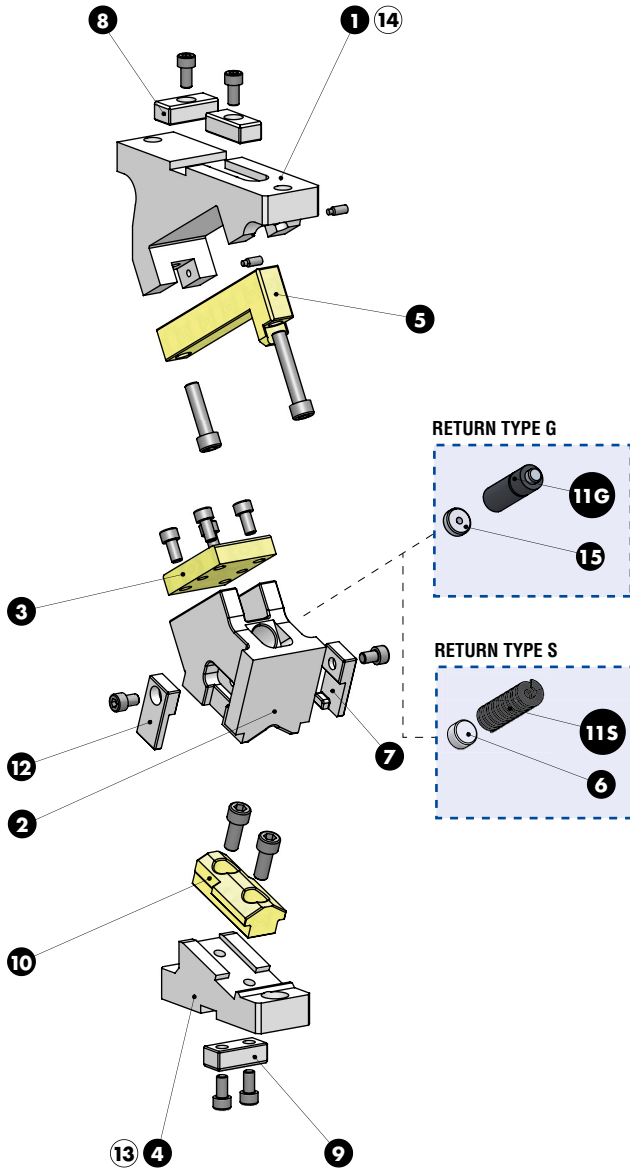



AERIAL CAM UNIT - OBEN HÄNGENDER SCHIEBER - UNITÀ A CAMME SOSPESA

SLIDER STRUCTURE, POSITIVE RETURN STRUCTURE AND CLEARANCES

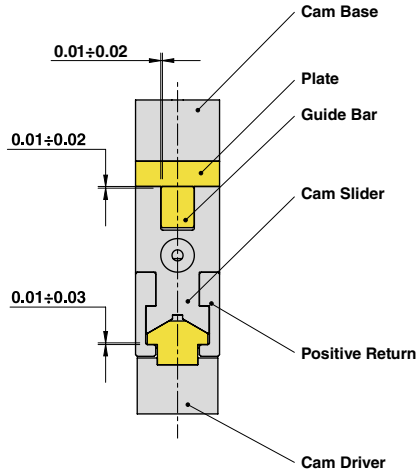

Cam Units CHD

PART LIST

Particular number	Description	Material	Quantity
1	Cam Base	CK45	1
2	Cam Slider	GG-30	1
3	Plate	CuZn25Al5 + Graphite - HB > 190	1
4	Cam Driver	CK45	1
5	Guide Bar	CuZn25Al5 + Graphite - HB > 190	1
6	Spring Spacer	CK45	1
7	Positive Return R	42CrMo4 Nitrided	1
8	Key	CK45	2
9	Key	CK45	1
10	Male "V" Driver	CuZn25Al5 + Graphite - HB > 190	1
11G	Gas Spring - Return Type G	-	1
11S	Spring - Return Type S	-	1
12	Positive Return L	42CrMo4 Nitrided	1
13	Cam Driver Fixing Screws M12x35 DIN 912	-	2
14	Cam Base Fixing Screws M12x45 DIN 912	-	2
15	Gas Spring Spacer	CK45	1



AERIAL CAM UNIT - OBEN HÄNGENDER SCHIEBER - UNITÀ A CAMME SOSPESA

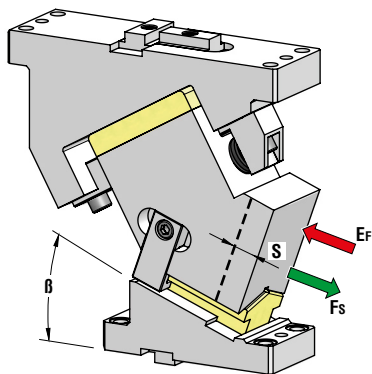

WEB

WEB

WEB

P.682

OMCR CODE	Work Angle	Stroke (mm)	Max Work Force with shoulder (kN)	Extraction Force (kN)	
	β			S	F _s
CHD080.00	0°	30,21	149	1,37	1,85
CHD080.05	5°	30,52	149	1,37	1,76
CHD080.10	10°	31,11	149	1,37	1,69
CHD080.15	15°	33,92	149	1,37	1,69
CHD080.20	20°	32,26	149	1,25	1,59
CHD080.25	25°	35	149	1,25	1,59
CHD080.30	30°	34,72	149	1,25	1,54
CHD080.35	35°	37,73	149	1,25	1,54
CHD080.40	40°	39,85	149	1,25	1,52
CHD080.45	45°	43,67	149	1,25	1,52
CHD080.50	50°	46,67	149	1,13	1,50
CHD080.55	55°	53,84	149	1,25	1,52
CHD080.60	60°	61,06	149	1,25	1,52
CHD080.65	65°	70,85	149	1,25	1,52

OPTION CODE

SL	1 ÷ 60 (1mm steps)
----	--------------------

*Return Type: G = Gas Spring / S = Spring



Art.	Work Angle = 5°	Return Type*	OPTION CODE
CHD080	05	G	SL55

OMCR CODE	Work Angle	Overall Dimensions (mm)				
	β	A	B	C	D	E
CHD080.00	0°	277	110	135	305	65
CHD080.05	5°	278,32	115,67	125	295	65
CHD080.10	10°	274,54	117,32	110	280	65
CHD080.15	15°	277,58	119,95	105	275	55
CHD080.20	20°	273,34	123,52	95	265	55
CHD080.25	25°	268,75	128,03	80	250	55
CHD080.30	30°	261,73	133,42	65	235	60
CHD080.35	35°	258,20	139,66	55	225	60
CHD080.40	40°	245,09	146,70	35	205	50
CHD080.45	45°	245,34	154,49	30	200	50
CHD080.50	50°	225,87	162,97	5	175	50
CHD080.55	55°	229,64	172,07	0	170	60
CHD080.60	60°	208,58	181,73	-20	150	50
CHD080.65	65°	203,67	191,87	-30	140	50



AERIAL CAM UNIT - OBEN HÄNGENDER SCHIEBER - UNITÀ A CAMME SOSPESA

X VIEW

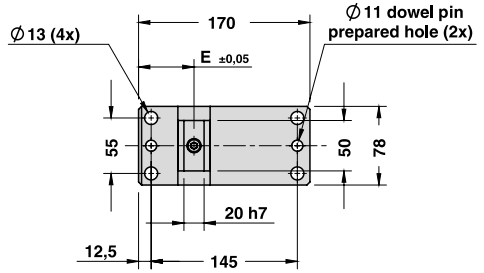
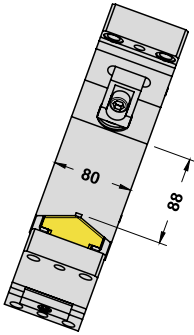

CAM DIAGRAM

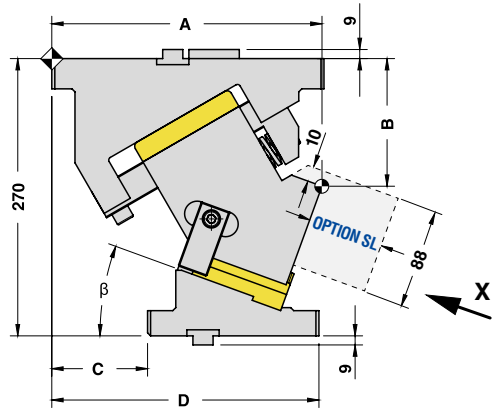
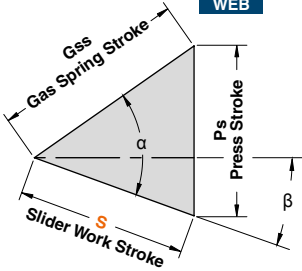

Work Angle	Inner Angle	Slider Work Stroke (mm)	Press Stroke (mm)	Gas Spring Stroke (mm)
β	α	S	Ps	Gss
0°	50°	30,21	36,00	47
5°	50°	30,52	33,07	43
10°	50°	31,11	31,11	40
15°	50°	33,92	31,72	40
20°	50°	32,26	28,53	35
25°	50°	35,00	29,58	35
30°	50°	34,72	28,31	32
35°	50°	37,73	29,93	32
40°	50°	39,85	31,00	31
45°	50°	43,67	33,58	31
50°	50°	46,67	35,75	30
55°	50°	53,84	41,40	31
60°	50°	61,06	47,49	31
65°	50°	70,85	56,19	31

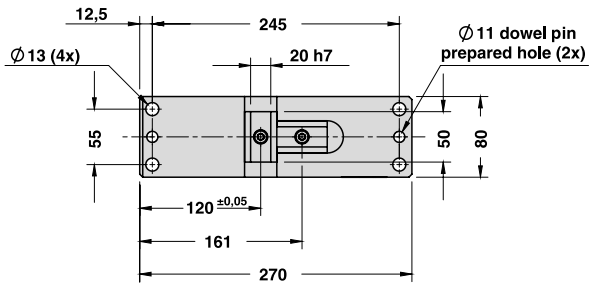



AERIAL CAM UNIT - OBEN HÄNGENDER SCHIEBER - UNITÀ A CAMME SOSPESA

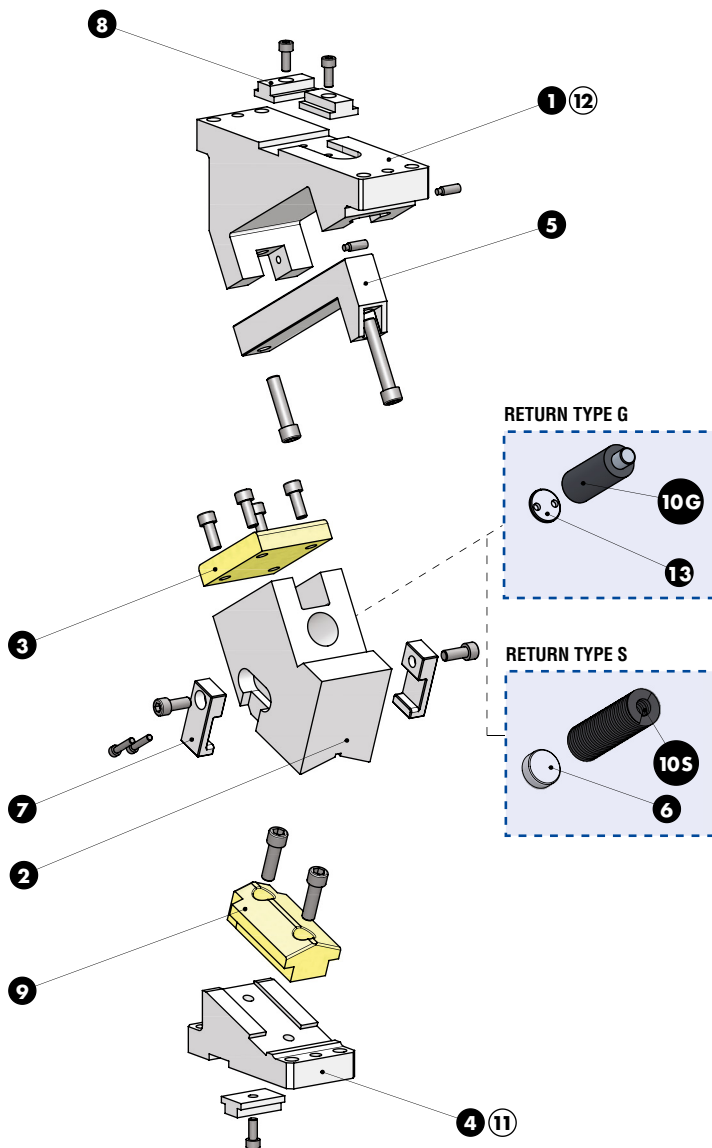



AERIAL CAM UNIT - OBEN HÄNGENDER SCHIEBER - UNITÀ A CAMME SOSPESA

SLIDER STRUCTURE, POSITIVE RETURN STRUCTURE AND CLEARANCES

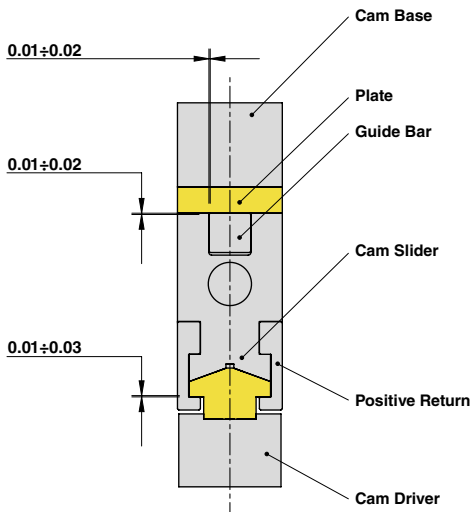

Cam Units CHD

PART LIST

Particular number	Description	Material	Quantity
1	Cam Base	GG-30	1
2	Cam Slider	GG-30	1
3	Plate	CuZn25Al5 + Graphite - HB > 190	1
4	Cam Driver	GG-30	1
5	Guide Bar	CK45 + Graphite	1
6	Spring Spacer	CK45	1
7	Positive Return	42CrMo4 Nitrided	2
8	Key	CK45	3
9	Male "V" Driver	CuZn25Al5 + Graphite - HB > 190	1
10G	Gas Spring - Return Type G	-	1
10S	Spring - Return Type S	-	1
11	Cam Driver Fixing Screws M12x50 DIN 912	-	4
12	Cam Base Fixing Screws M12x55 DIN 912	-	4
13	Gas Spring Spacer	CK45	1



AERIAL CAM UNIT - OBEN HÄNGENDER SCHIEBER - UNITÀ A CAMME SOSPESA

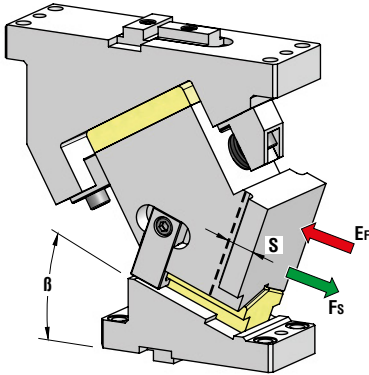

OMCR CODE	Work Angle	Stroke (mm)	Max Work Force with shoulder (kN)	Extraction Force (kN)	
	β	S	F _s	Spring	Gas Spring
CHD100.00	0°	30,21	149	1,37	1,85
CHD100.05	5°	30,52	149	1,37	1,76
CHD100.10	10°	31,11	149	1,37	1,69
CHD100.15	15°	33,92	149	1,37	1,69
CHD100.20	20°	32,26	149	1,25	1,59
CHD100.25	25°	35	149	1,25	1,59
CHD100.30	30°	34,72	149	1,25	1,54
CHD100.35	35°	37,73	149	1,25	1,54
CHD100.40	40°	39,85	149	1,25	1,52
CHD100.45	45°	43,67	149	1,25	1,52
CHD100.50	50°	46,67	149	1,13	1,50
CHD100.55	55°	53,84	149	1,25	1,52
CHD100.60	60°	61,06	149	1,25	1,52
CHD100.65	65°	70,85	149	1,25	1,52

OPTION CODE

SL	1 ÷ 60 (1mm steps)
----	--------------------

*Return Type: G = Gas Spring / S = Spring



Art.	Work Angle = 5°	Return Type*	OPTION CODE
CHD100	05	G	SL55

OMCR CODE	Work Angle	Overall Dimensions (mm)				
	β	A	B	C	D	E
CHD100.00	0°	277	110	135	305	65
CHD100.05	5°	278,32	115,67	125	295	65
CHD100.10	10°	274,54	117,32	110	280	65
CHD100.15	15°	277,58	119,95	105	275	55
CHD100.20	20°	273,34	123,52	95	265	55
CHD100.25	25°	268,75	128,03	80	250	55
CHD100.30	30°	261,73	133,42	65	235	60
CHD100.35	35°	258,20	139,66	55	225	60
CHD100.40	40°	245,09	146,70	35	205	50
CHD100.45	45°	245,34	154,49	30	200	50
CHD100.50	50°	225,87	162,97	5	175	50
CHD100.55	55°	229,64	172,07	0	170	60
CHD100.60	60°	208,58	181,73	-20	150	50
CHD100.65	65°	203,67	191,87	-30	140	50



AERIAL CAM UNIT - OBEN HÄNGENDER SCHIEBER - UNITÀ A CAMME SOSPESA

X VIEW

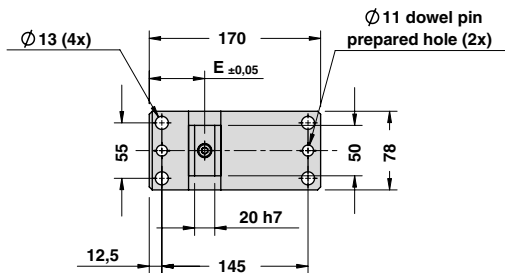
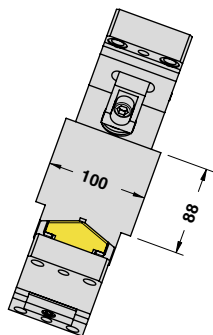

CAM DIAGRAM

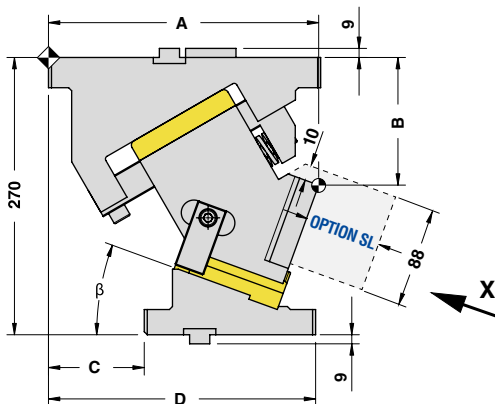
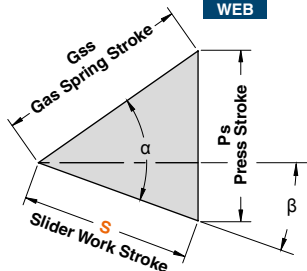

Work Angle	Inner Angle	Slider Work Stroke (mm)	Press Stroke (mm)	Gas Spring Stroke (mm)
β	α	S	Ps	Gss
0°	50°	30,21	36,00	47
5°	50°	30,52	33,07	43
10°	50°	31,11	31,11	40
15°	50°	33,92	31,72	40
20°	50°	32,26	28,53	35
25°	50°	35,00	29,58	35
30°	50°	34,72	28,31	32
35°	50°	37,73	29,93	32
40°	50°	39,85	31,00	31
45°	50°	43,67	33,58	31
50°	50°	46,67	35,75	30
55°	50°	53,84	41,40	31
60°	50°	61,06	47,49	31
65°	50°	70,85	56,19	31

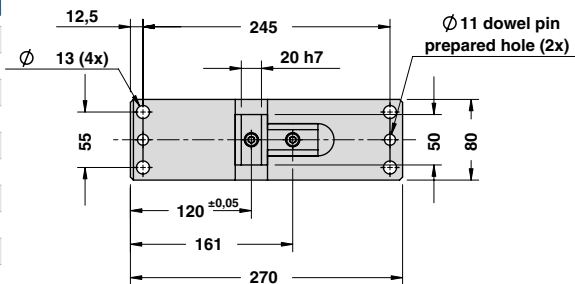

Cam Units CHD

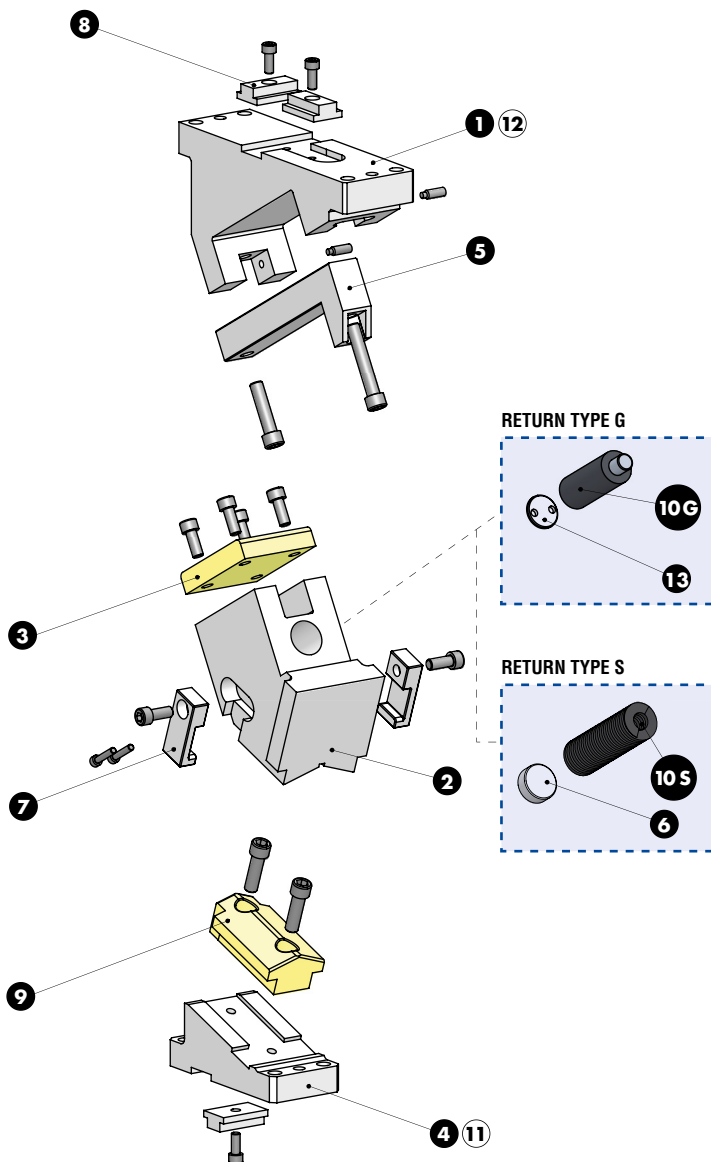
**AERIAL CAM UNIT - OBEN HÄNGENDER SCHIEBER - UNITÀ A CAMME SOSPESA**



AERIAL CAM UNIT - OBEN HÄNGENDER SCHIEBER - UNITÀ A CAMME SOSPESA

SLIDER STRUCTURE, POSITIVE RETURN STRUCTURE AND CLEARANCES

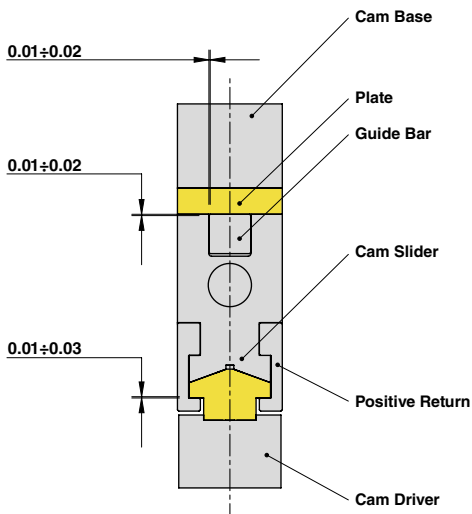

Cam Units CHD

PART LIST

Particular number	Description	Material	Quantity
1	Cam Base	GG-30	1
2	Cam Slider	GG-30	1
3	Plate	CuZn25Al5 + Graphite - HB > 190	1
4	Cam Driver	GG-30	1
5	Guide Bar	CK45 + Graphite	1
6	Spring Spacer	CK45	1
7	Positive Return	42CrMo4 Nitrided	2
8	Key	CK45	3
9	Male "V" Driver	CuZn25Al5 + Graphite - HB > 190	1
10G	Gas Spring - Return Type G	-	1
10S	Spring - Return Type S	-	1
11	Cam Driver Fixing Screws M12x50 DIN 912	-	4
12	Cam Base Fixing Screws M12x55 DIN 912	-	4
13	Gas Spring Spacer	CK45	1



AERIAL CAM UNIT - OBEN HÄNGENDER SCHIEBER - UNITÀ A CAMME SOSPESA

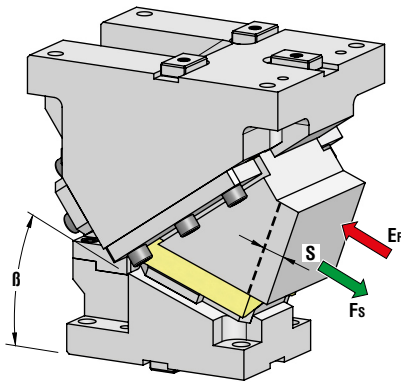

OMCR CODE	Work Angle β	Stroke (mm) S	Max Work Force with shoulder (kN) Fs	Extraction Force (kN) Ef	
				Spring	Gas Spring
CHD150.00	0°	28,68	391	2,29	7,15
CHD150.05	5°	32,26	391	2,29	7,15
CHD150.10	10°	35,90	391	2,29	7,15
CHD150.15	15°	39,65	391	2,29	7,15
CHD150.20	20°	43,59	391	2,29	7,15
CHD150.25	25°	47,78	391	2,29	7,15
CHD150.30	30°	52,33	391	2,29	7,15
CHD150.35	35°	57,36	391	2,29	7,15
CHD150.40	40°	63,05	391	2,29	7,15
CHD150.45	45°	69,64	391	2,29	7,15
CHD150.50	50°	77,49	391	2,29	7,15
CHD150.55	55°	87,17	391	2,29	7,15
CHD150.60	60°	99,62	391	2,29	7,15
CHD150.65	65°	116,51	391	2,29	7,15

*Return Type: G = Gas Spring / S = Spring



Art.	Work Angle = 5°	Return Type*
CHD150	05	G

OMCR CODE	Work Angle β	Overall Dimensions (mm)				
		A	B	C	D	E
CHD150.00	0°	325	130	80	310	25
CHD150.05	5°	319,70	133,26	60	290	25
CHD150.10	10°	319,06	137,79	45	275	25
CHD150.15	15°	322,98	143,56	35	265	20
CHD150.20	20°	326,33	150,51	25	255	15
CHD150.25	25°	329,03	158,61	15	245	10
CHD150.30	30°	325,98	167,78	0	230	0
CHD150.35	35°	322,08	192,95	-15	215	0
CHD150.40	40°	312,26	204,06	-35	195	0
CHD150.45	45°	306,42	216,01	-50	180	0
CHD150.50	50°	294,51	228,71	-70	160	0
CHD150.55	55°	281,46	242,07	-90	140	0
CHD150.60	60°	272,22	255,98	-105	125	0
CHD150.65	65°	261,75	270,34	-120	110	0



AERIAL CAM UNIT - OBEN HÄNGENDER SCHIEBER - UNITÀ A CAMME SOSPESA

X VIEW

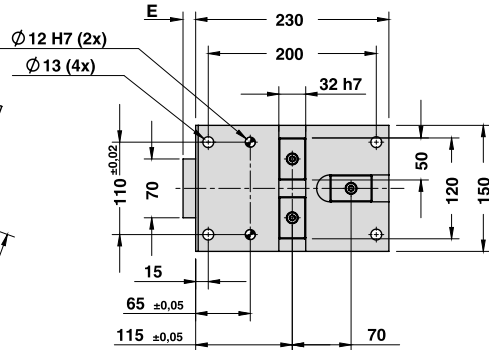
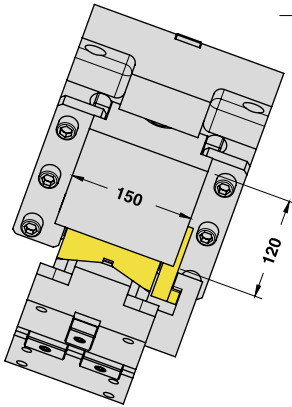

CAM DIAGRAM

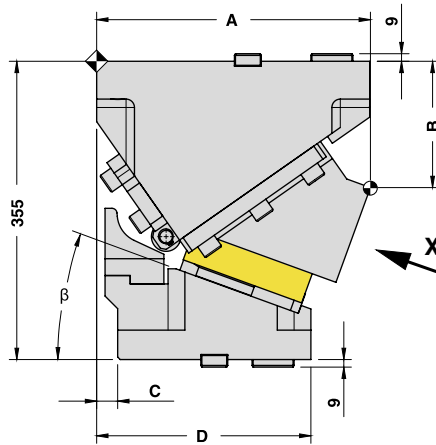
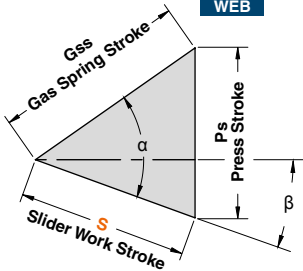

Work Angle	Inner Angle	Slider Work Stroke (mm)	Press Stroke (mm)	Gas Spring Stroke (mm)
β	α	S	Ps	Gss
0°	55°	28,68	40,96	50
5°	55°	32,26	41,11	50
10°	55°	35,90	41,59	50
15°	55°	39,65	42,40	50
20°	55°	43,59	43,59	50
25°	55°	47,78	45,19	50
30°	55°	52,33	47,29	50
35°	55°	57,36	50,00	50
40°	55°	63,05	53,47	50
45°	55°	69,64	57,92	50
50°	55°	77,49	63,72	50
55°	55°	87,17	71,41	50
60°	55°	99,62	81,92	50
65°	55°	116,51	96,91	50

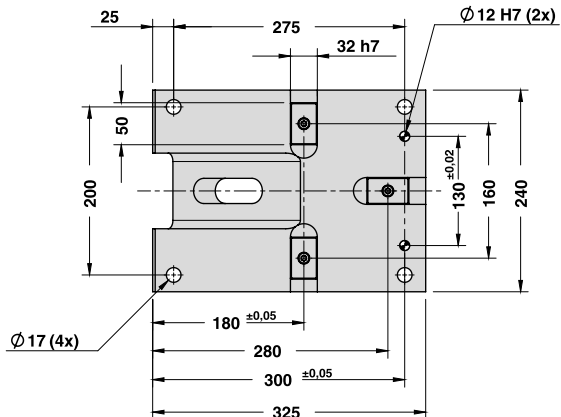

Cam Units CHD



AERIAL CAM UNIT - OBEN HÄNGENDER SCHIEBER - UNITÀ A CAMME SOSPESA

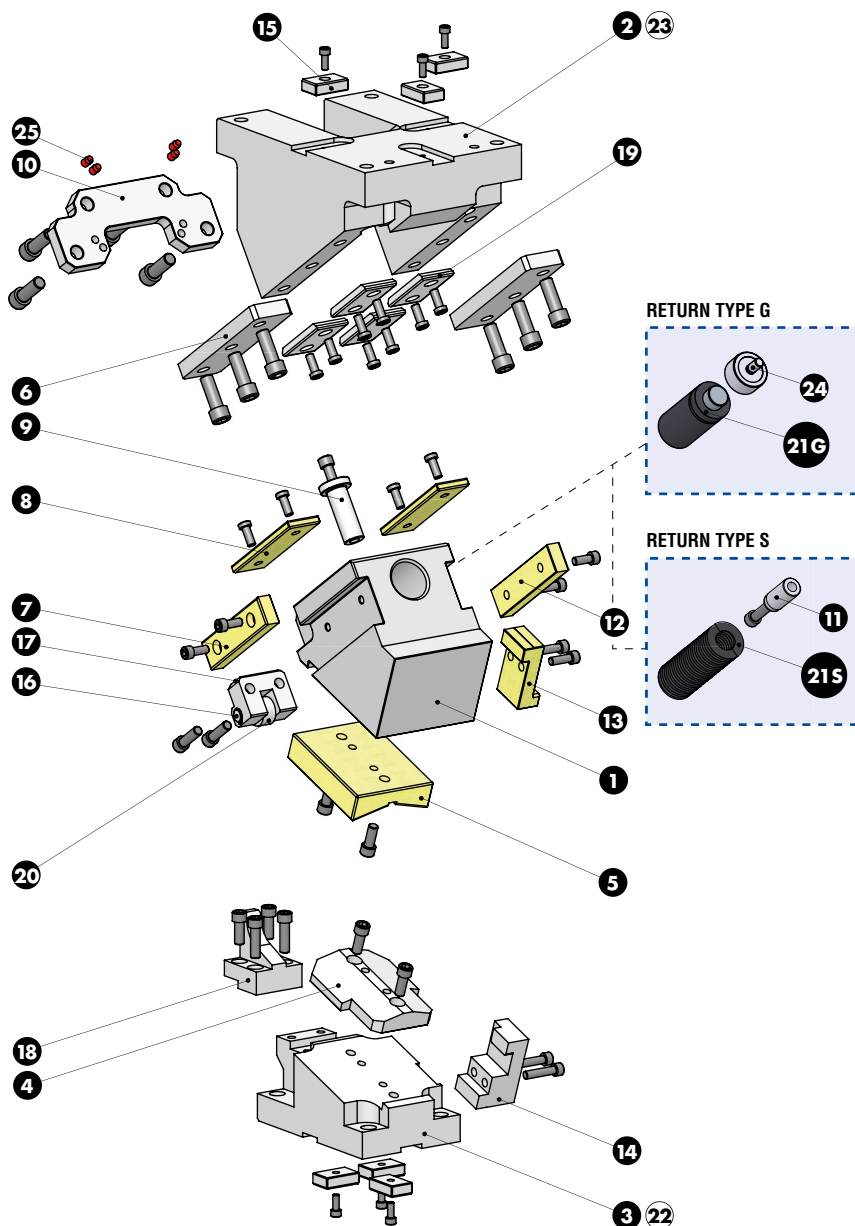



AERIAL CAM UNIT - OBEN HÄNGENDER SCHIEBER - UNITÀ A CAMME SOSPESA

SLIDER STRUCTURE, POSITIVE RETURN STRUCTURE AND CLEARANCES

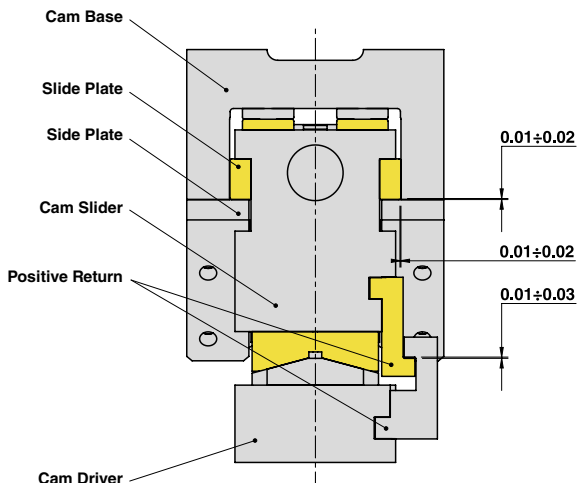

PART LIST

Particular number	Description	Material	Quantity
1	Cam Slider	GG-30	1
2	Cam Base	GG-30	1
3	Cam Driver	GG-30	1
4	Male "V" Driver	CK45	1
5	Female "V" Driver	CuZn25Al5 + Graphite - HB > 190	1
6	Side Plate	CK45	2
7	Slide Plate L	CuZn25Al5 + Graphite - HB > 190	1
8	Wear Plate	CuZn25Al5 + Graphite - HB > 190	2
9	Safety Pin	CK45	1
10	Stopper Plate	St 52	1
11	Spring Guide Pin	CK45	1
12	Slide Plate R	CuZn25Al5 + Graphite - HB > 190	1
13	Positive Return	CuZn25Al5 - HB > 190	1
14	Positive Return	42CrMo4 Nitrided	1
15	Key	CK45	6
16	Shaft	CK45	1
17	Roller Bracket	CK45	1
18	Accelerator	CK45	1
19	Wear Plate	CK45	4
20	Roller	NATR15PP	1
21G	Gas Spring - Return Type G	-	1
21S	Spring - Return Type S	-	1
22	Cam Driver Fixing Screws M12x50 DIN 912	-	4
23	Cam Base Fixing Screws M16x70 DIN 912	-	4
24	Gas Spring Spacer	CK45	1
25	Elastomer Cap	Elastomer 92SH	4



AERIAL CAM UNIT - OBEN HÄNGENDER SCHIEBER - UNITÀ A CAMME SOSPESA

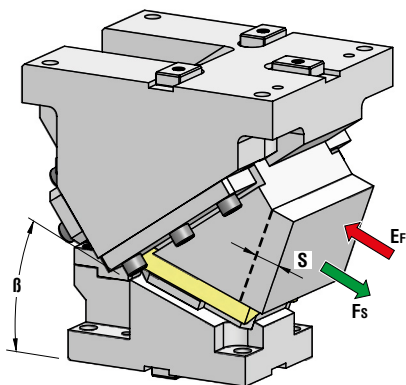

OMCR CODE	Work Angle β	Stroke (mm) S	Max Work Force with shoulder (kN) F _s	Extraction Force (kN) E _f	
				Spring	Gas Spring
CHD180.00	0°	28,68	396	2,29	7,15
CHD180.05	5°	32,26	396	2,29	7,15
CHD180.10	10°	35,90	396	2,29	7,15
CHD180.15	15°	39,65	396	2,29	7,15
CHD180.20	20°	43,59	396	2,29	7,15
CHD180.25	25°	47,78	396	2,29	7,15
CHD180.30	30°	52,33	396	2,29	7,15
CHD180.35	35°	57,36	396	2,29	7,15
CHD180.40	40°	63,05	396	2,29	7,15
CHD180.45	45°	69,64	396	2,29	7,15
CHD180.50	50°	77,49	396	2,29	7,15
CHD180.55	55°	87,17	396	2,29	7,15
CHD180.60	60°	99,62	396	2,29	7,15
CHD180.65	65°	116,51	396	2,29	7,15

*Return Type: G = Gas Spring / S = Spring



Art.	Work Angle = 5°	Return Type*
CHD180	05	G

OMCR CODE	Work Angle β	Overall Dimensions (mm)				
		A	B	C	D	E
CHD180.00	0°	325	130	80	310	25
CHD180.05	5°	319,70	133,26	60	290	25
CHD180.10	10°	319,06	137,79	45	275	25
CHD180.15	15°	322,98	143,56	35	265	20
CHD180.20	20°	326,33	150,51	25	255	15
CHD180.25	25°	329,03	158,61	15	245	10
CHD180.30	30°	325,98	167,78	0	230	0
CHD180.35	35°	322,08	192,95	-15	215	0
CHD180.40	40°	312,26	204,06	-35	195	0
CHD180.45	45°	306,42	216,01	-50	180	0
CHD180.50	50°	294,51	228,71	-70	160	0
CHD180.55	55°	281,46	242,07	-90	140	0
CHD180.60	60°	272,22	255,98	-105	125	0
CHD180.65	65°	261,75	270,34	-120	110	0



AERIAL CAM UNIT - OBEN HÄNGENDER SCHIEBER - UNITÀ A CAMME SOSPESA

X VIEW

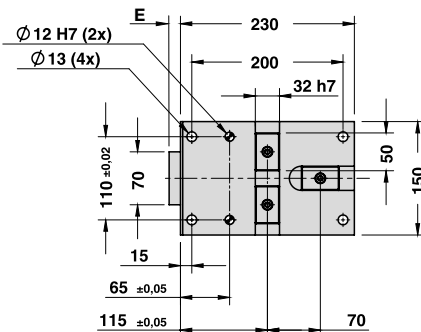
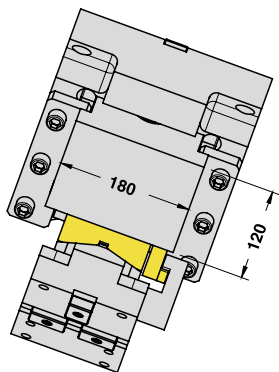

CAM DIAGRAM

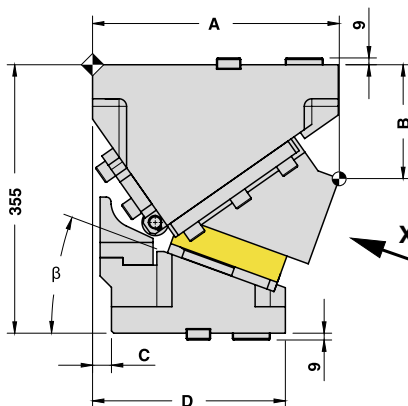
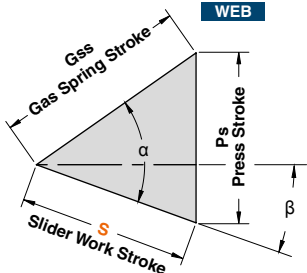

Work Angle	Inner Angle	Slider Work Stroke (mm)	Press Stroke (mm)	Gas Spring Stroke (mm)
β	α	S	Ps	Gss
0°	55°	28,68	40,96	50
5°	55°	32,26	41,11	50
10°	55°	35,90	41,59	50
15°	55°	39,65	42,40	50
20°	55°	43,59	43,59	50
25°	55°	47,78	45,19	50
30°	55°	52,33	47,29	50
35°	55°	57,36	50,00	50
40°	55°	63,05	53,47	50
45°	55°	69,64	57,92	50
50°	55°	77,49	63,72	50
55°	55°	87,17	71,41	50
60°	55°	99,62	81,92	50
65°	55°	116,51	96,91	50

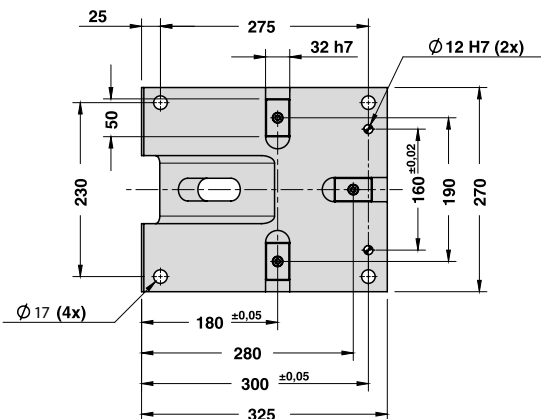

Cam Units CHD



AERIAL CAM UNIT - OBEN HÄNGENDER SCHIEBER - UNITÀ A CAMME SOSPESA

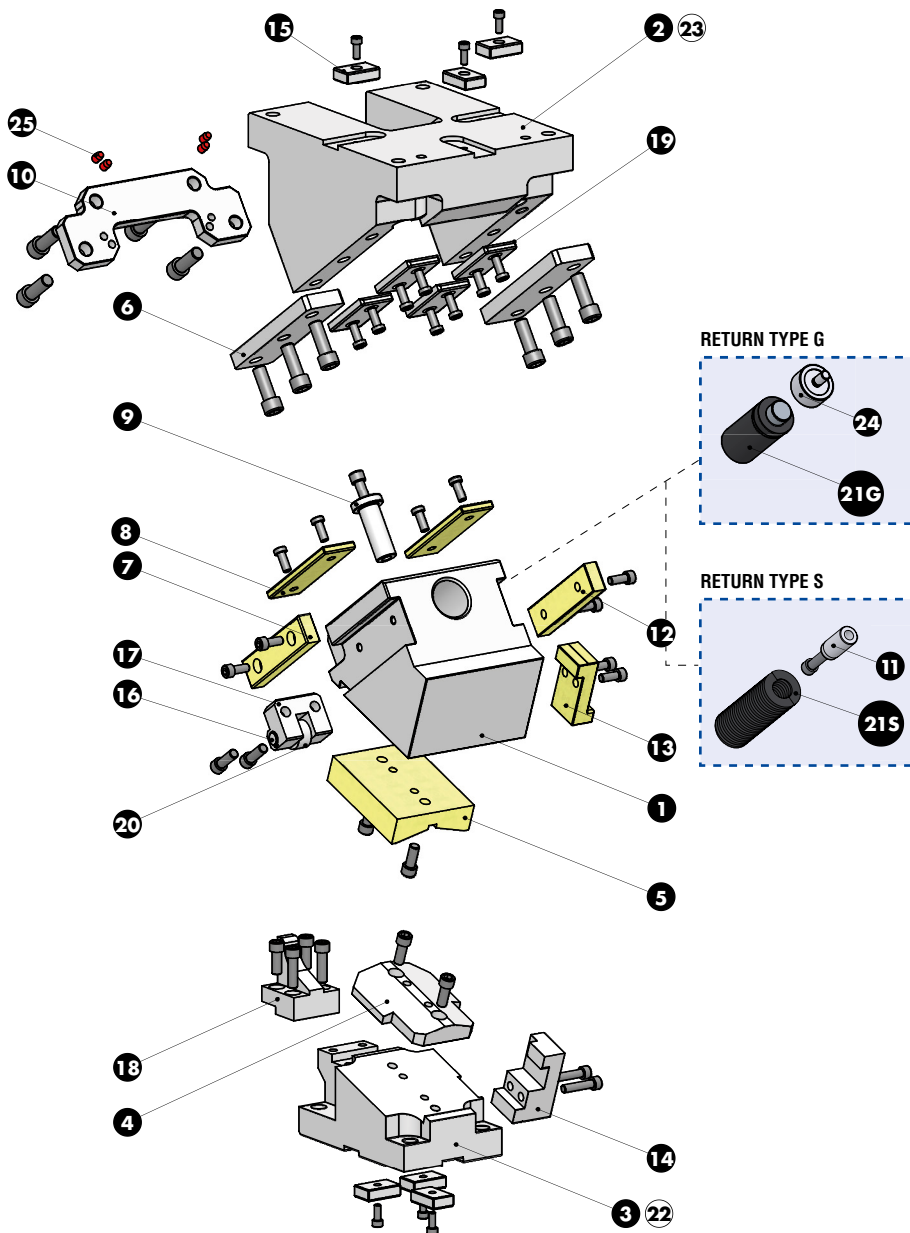



AERIAL CAM UNIT - OBEN HÄNGENDER SCHIEBER - UNITÀ A CAMME SOSPESA

SLIDER STRUCTURE, POSITIVE RETURN STRUCTURE AND CLEARANCES

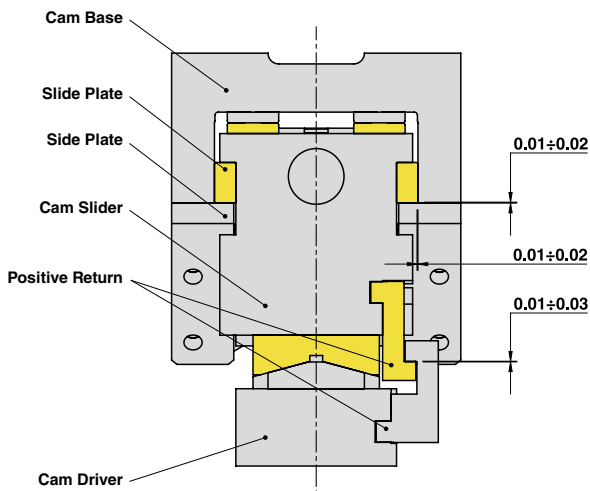

PART LIST

Particular number	Description	Material	Quantity
1	Cam Slider	GG-30	1
2	Cam Base	GG-30	1
3	Cam Driver	GG-30	1
4	Male "V" Driver	CK45	1
5	Female "V" Driver	CuZn25Al5 + Graphite - HB > 190	1
6	Side Plate	CK45	2
7	Slide Plate L	CuZn25Al5 + Graphite - HB > 190	1
8	Wear Plate	CuZn25Al5 + Graphite - HB > 190	2
9	Safety Pin	CK45	1
10	Stopper Plate	St 52	1
11	Spring Guide Pin	CK45	1
12	Slide Plate R	CuZn25Al5 + Graphite - HB > 190	1
13	Positive Return	CuZn25Al5 - HB > 190	1
14	Positive Return	42CrMo4 Nitrided	1
15	Key	CK45	6
16	Shaft	CK45	1
17	Roller Bracket	CK45	1
18	Accelerator	CK45	1
19	Wear Plate	CK45	4
20	Roller	NATR15PP	1
21G	Gas Spring - Return Type G	-	1
21S	Spring - Return Type S	-	1
22	Cam Driver Fixing Screws M12x50 DIN 912	-	4
23	Cam Base Fixing Screws M16x70 DIN 912	-	4
24	Gas Spring Spacer	CK45	1
25	Elastomer Cap	Elastomer 92SH	4



AERIAL CAM UNIT - OBEN HÄNGENDER SCHIEBER - UNITÀ A CAMME SOSPESA

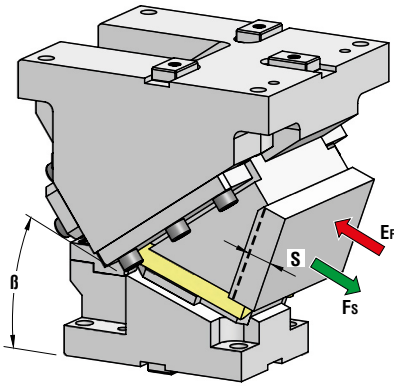

OMCR CODE	Work Angle β	Stroke (mm) S	Max Work Force with shoulder (kN) Fs	Extraction Force (kN) Ef	
				Spring	Gas Spring
CHD200.00	0°	28,68	396	2,29	7,15
CHD200.05	5°	32,26	396	2,29	7,15
CHD200.10	10°	35,90	396	2,29	7,15
CHD200.15	15°	39,65	396	2,29	7,15
CHD200.20	20°	43,59	396	2,29	7,15
CHD200.25	25°	47,78	396	2,29	7,15
CHD200.30	30°	52,33	396	2,29	7,15
CHD200.35	35°	57,36	396	2,29	7,15
CHD200.40	40°	63,05	396	2,29	7,15
CHD200.45	45°	69,64	396	2,29	7,15
CHD200.50	50°	77,49	396	2,29	7,15
CHD200.55	55°	87,17	396	2,29	7,15
CHD200.60	60°	99,62	396	2,29	7,15
CHD200.65	65°	116,51	396	2,29	7,15

*Return Type: G = Gas Spring / S = Spring

20



Art.	Work Angle = 5°	Return Type*
CHD200	05	G

OMCR CODE	Work Angle β	Overall Dimensions (mm)				
		A	B	C	D	E
CHD200.00	0°	325	130	80	310	25
CHD200.05	5°	319,70	133,26	60	290	25
CHD200.10	10°	319,06	137,79	45	275	25
CHD200.15	15°	322,98	143,56	35	265	20
CHD200.20	20°	326,33	150,51	25	255	15
CHD200.25	25°	329,03	158,61	15	245	10
CHD200.30	30°	325,98	167,78	0	230	0
CHD200.35	35°	322,08	192,95	-15	215	0
CHD200.40	40°	312,26	204,06	-35	195	0
CHD200.45	45°	306,42	216,01	-50	180	0
CHD200.50	50°	294,51	228,71	-70	160	0
CHD200.55	55°	281,46	242,07	-90	140	0
CHD200.60	60°	272,22	255,98	-105	125	0
CHD200.65	65°	261,75	270,34	-120	110	0



AERIAL CAM UNIT - OBEN HÄNGENDER SCHIEBER - UNITÀ A CAMME SOSPESA

X VIEW

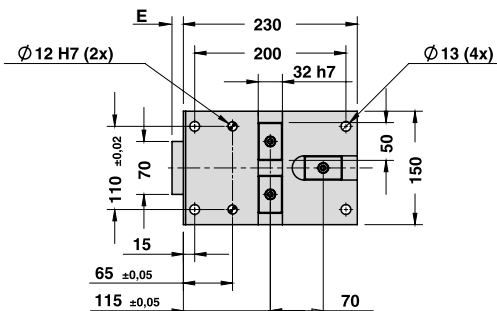
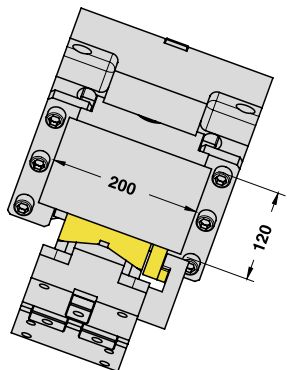

CAM DIAGRAM

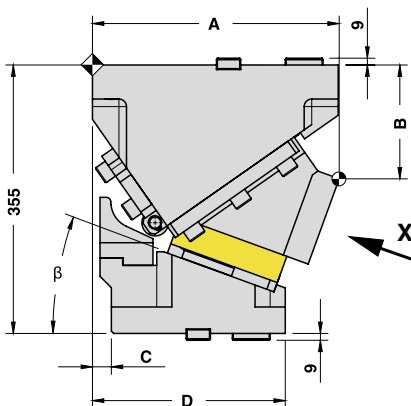
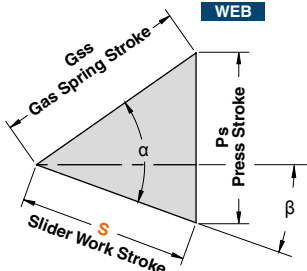

Work Angle	Inner Angle	Slider Work Stroke (mm)	Press Stroke (mm)	Gas Spring Stroke (mm)
β	α	S	Ps	Gss
0°	55°	28,68	40,96	50
5°	55°	32,26	41,11	50
10°	55°	35,90	41,59	50
15°	55°	39,65	42,40	50
20°	55°	43,59	43,59	50
25°	55°	47,78	45,19	50
30°	55°	52,33	47,29	50
35°	55°	57,36	50,00	50
40°	55°	63,05	53,47	50
45°	55°	69,64	57,92	50
50°	55°	77,49	63,72	50
55°	55°	87,17	71,41	50
60°	55°	99,62	81,92	50
65°	55°	116,51	96,91	50

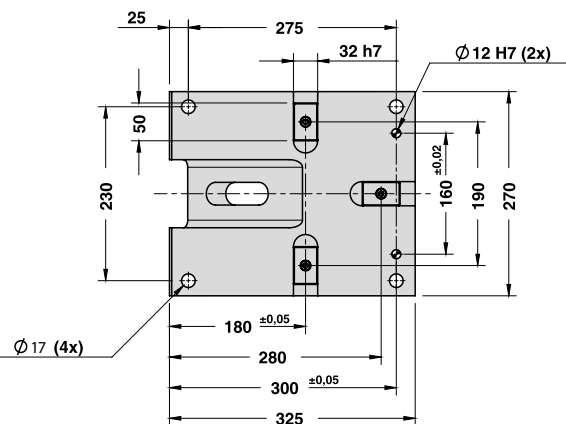

Cam Units CHD



AERIAL CAM UNIT - OBEN HÄNGENDER SCHIEBER - UNITÀ A CAMME SOSPESA

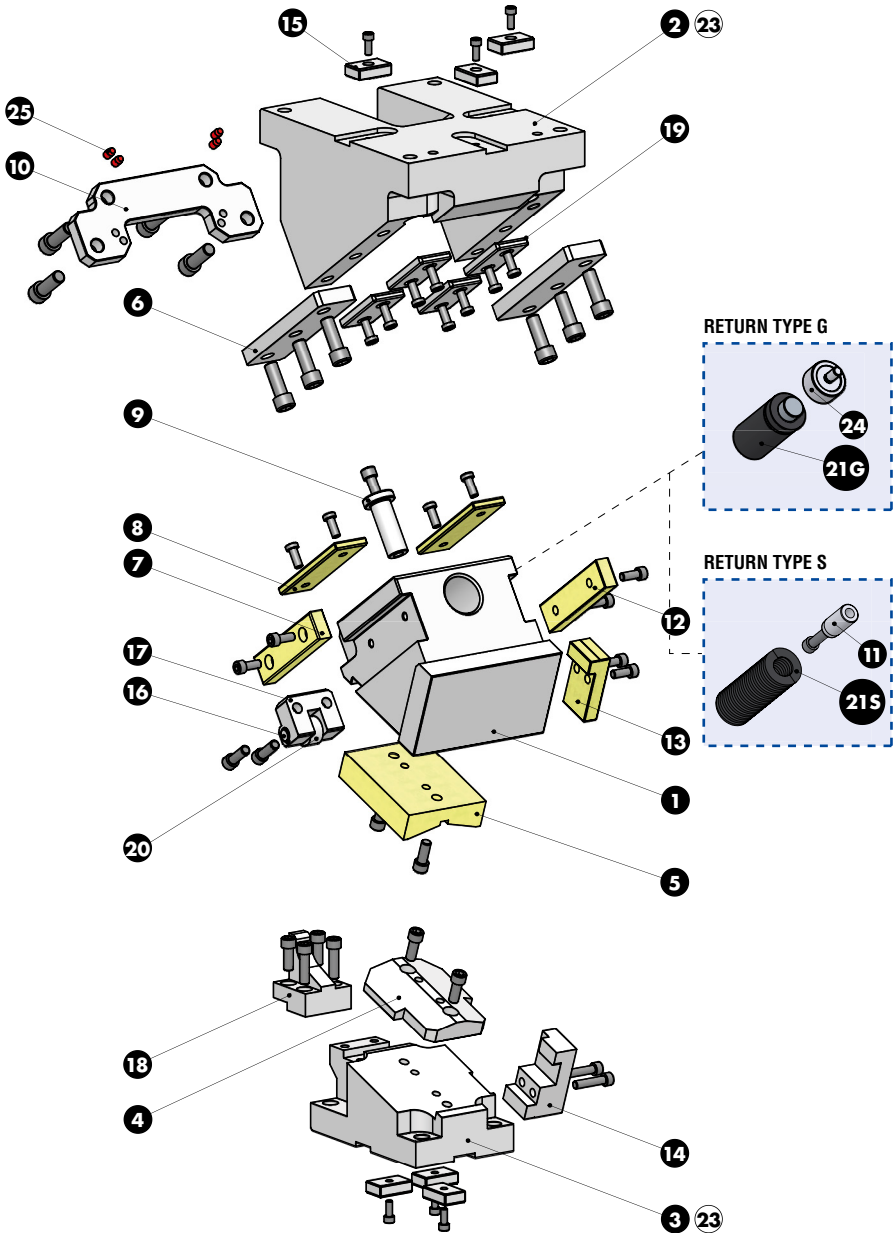



AERIAL CAM UNIT - OBEN HÄNGENDER SCHIEBER - UNITÀ A CAMME SOSPESA

SLIDER STRUCTURE, POSITIVE RETURN STRUCTURE AND CLEARANCES

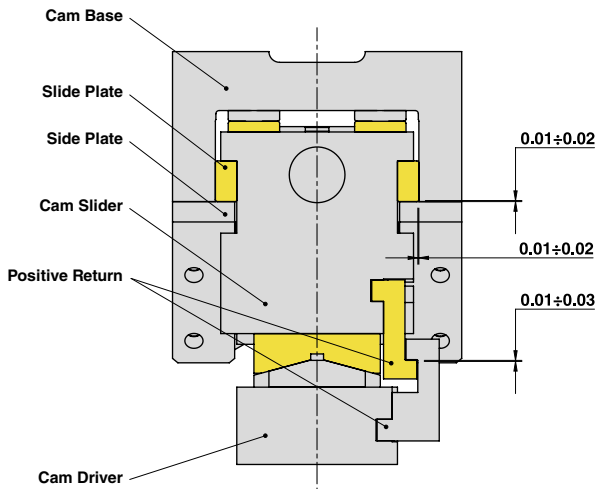

PART LIST

Particular number	Description	Material	Quantity
1	Cam Slider	GG-30	1
2	Cam Base	GG-30	1
3	Cam Driver	GG-30	1
4	Male "V" Driver	CK45	1
5	Female "V" Driver	CuZn25Al5 + Graphite - HB > 190	1
6	Side Plate	CK45	2
7	Slide Plate L	CuZn25Al5 + Graphite - HB > 190	1
8	Wear Plate	CuZn25Al5 + Graphite - HB > 190	2
9	Safety Pin	CK45	1
10	Stopper Plate	St 52	1
11	Spring Guide Pin	CK45	1
12	Slide Plate R	CuZn25Al5 + Graphite - HB > 190	1
13	Positive Return	CuZn25Al5 - HB > 190	1
14	Positive Return	42CrMo4 Nitrided	1
15	Key	CK45	6
16	Shaft	CK45	1
17	Roller Bracket	CK45	1
18	Accelerator	CK45	1
19	Wear Plate	CK45	4
20	Roller	NATR15PP	1
21G	Gas Spring - Return Type G	-	1
21S	Spring - Return Type S	-	1
22	Cam Driver Fixing Screws M12x50 DIN 912	-	4
23	Cam Base Fixing Screws M16x70 DIN 912	-	4
24	Gas Spring Spacer	CK45	1
25	Elastomer Cap	Elastomer 92SH	4



AERIAL CAM UNIT - OBEN HÄNGENDER SCHIEBER - UNITÀ A CAMME SOSPESA

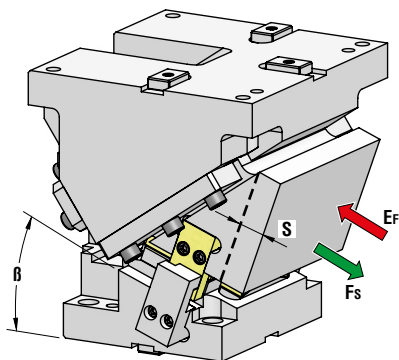

OMCR CODE	Work Angle β	Stroke (mm) S	Max Work Force with shoulder (kN) Fs	Extraction Force (kN) Ef	
				Spring	Gas Spring
CHD250.00	0°	28,68	645	4,58	14,30
CHD250.05	5°	32,26	645	4,58	14,30
CHD250.10	10°	35,90	645	4,58	14,30
CHD250.15	15°	39,65	645	4,58	14,30
CHD250.20	20°	43,59	645	4,58	14,30
CHD250.25	25°	47,78	645	4,58	14,30
CHD250.30	30°	52,33	645	4,58	14,30
CHD250.35	35°	57,36	645	4,58	14,30
CHD250.40	40°	63,05	645	4,58	14,30
CHD250.45	45°	69,64	645	4,58	14,30
CHD250.50	50°	77,49	645	4,58	14,30
CHD250.55	55°	87,17	645	4,58	14,30
CHD250.60	60°	99,62	645	4,58	14,30
CHD250.65	65°	116,51	645	4,58	14,30

*Return Type: G = Gas Spring / S = Spring



Art.	Work Angle = 5°	Return Type*
CHD250	05	G

OMCR CODE	Work Angle β	Overall Dimensions (mm)				
		A	B	C	D	E
CHD250.00	0°	325	90	80	310	25
CHD250.05	5°	323,19	93,41	60	290	25
CHD250.10	10°	326,01	98,40	45	275	25
CHD250.15	15°	333,33	104,92	35	265	20
CHD250.20	20°	340,02	112,93	25	255	15
CHD250.25	25°	345,94	122,35	15	245	10
CHD250.30	30°	345,98	133,14	0	230	0
CHD250.35	35°	345,03	160,19	-15	215	0
CHD250.40	40°	337,97	173,42	-35	195	0
CHD250.45	45°	334,71	187,72	-50	180	0
CHD250.50	50°	325,15	202,99	-70	160	0
CHD250.55	55°	314,23	219,12	-90	140	0
CHD250.60	60°	306,86	235,98	-105	125	0
CHD250.65	65°	298	253,44	-120	110	0



AERIAL CAM UNIT - OBEN HÄNGENDER SCHIEBER - UNITÀ A CAMME SOSPESA

X VIEW

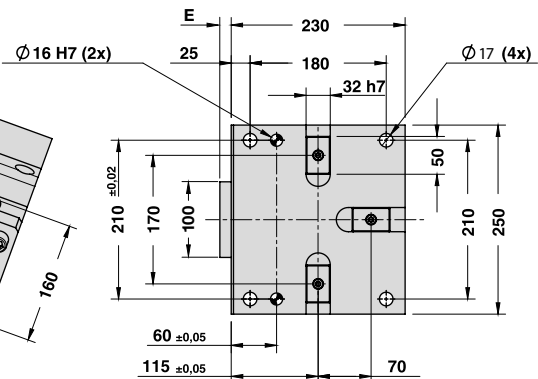
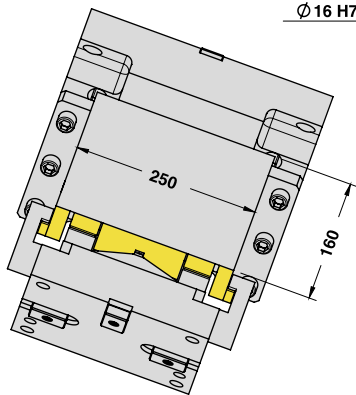

CAM DIAGRAM

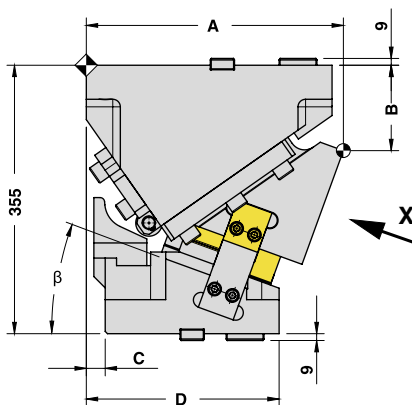
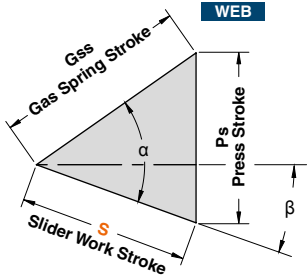

Work Angle	Inner Angle	Slider Work Stroke (mm)	Press Stroke (mm)	Gas Spring Stroke (mm)
β	α	S	Ps	Gss
0°	55°	28,68	40,96	50
5°	55°	32,26	41,11	50
10°	55°	35,90	41,59	50
15°	55°	39,65	42,40	50
20°	55°	43,59	43,59	50
25°	55°	47,78	45,19	50
30°	55°	52,33	47,29	50
35°	55°	57,36	50,00	50
40°	55°	63,05	53,47	50
45°	55°	69,64	57,92	50
50°	55°	77,49	63,72	50
55°	55°	87,17	71,41	50
60°	55°	99,62	81,92	50
65°	55°	116,51	96,91	50

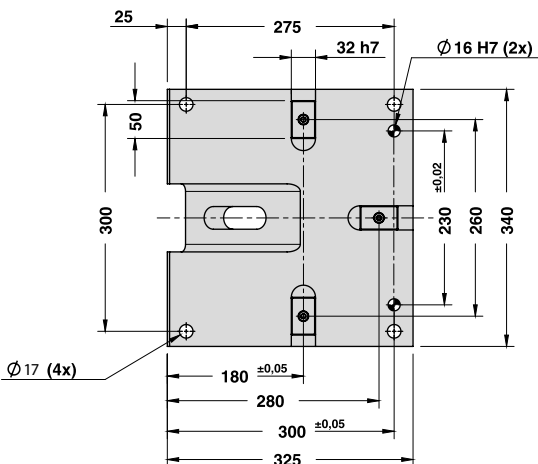

Cam Units CHD



AERIAL CAM UNIT - OBEN HÄNGENDER SCHIEBER - UNITÀ A CAMME SOSPESA

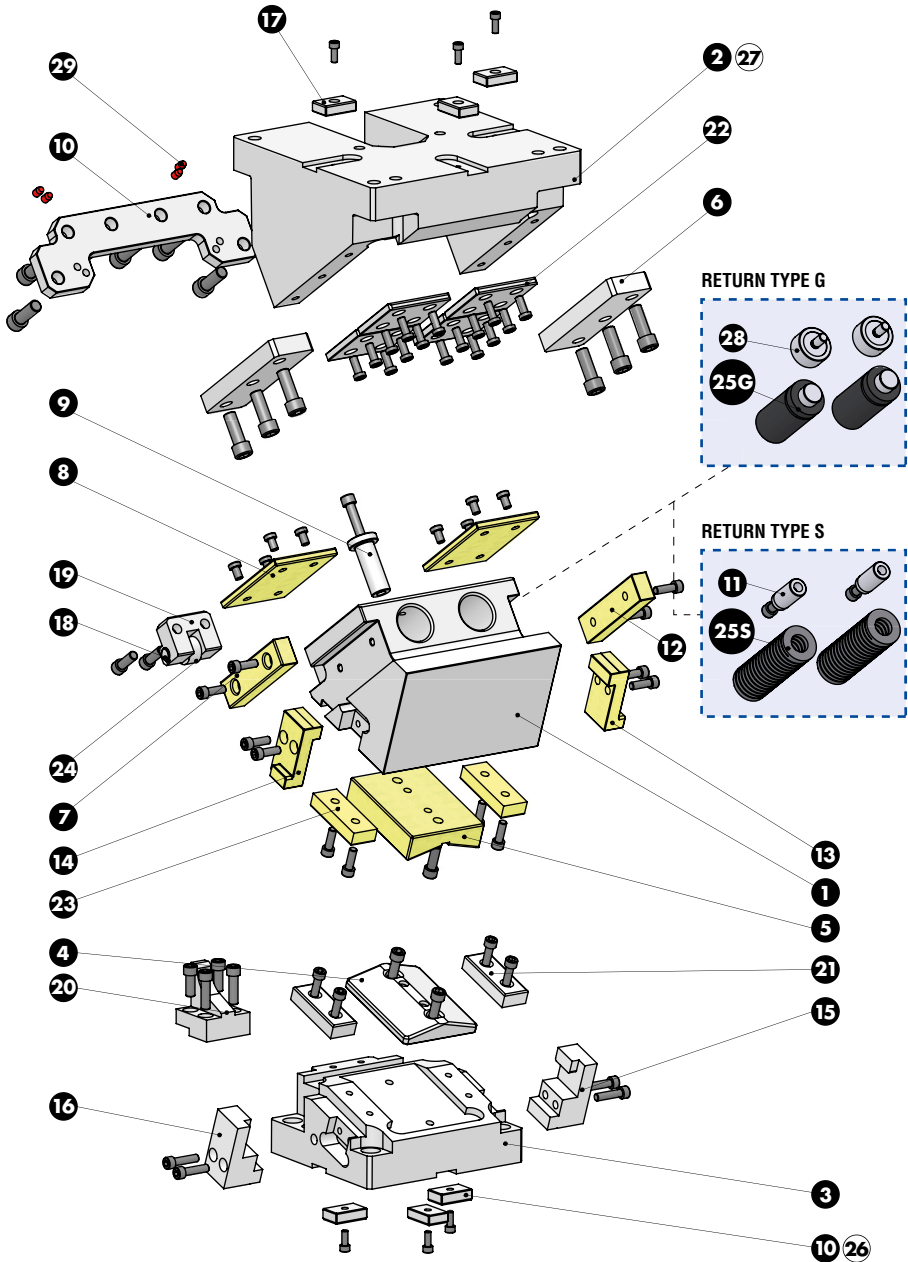



AERIAL CAM UNIT - OBEN HÄNGENDER SCHIEBER - UNITÀ A CAMME SOSPESA

SLIDER STRUCTURE, POSITIVE RETURN STRUCTURE AND CLEARANCES

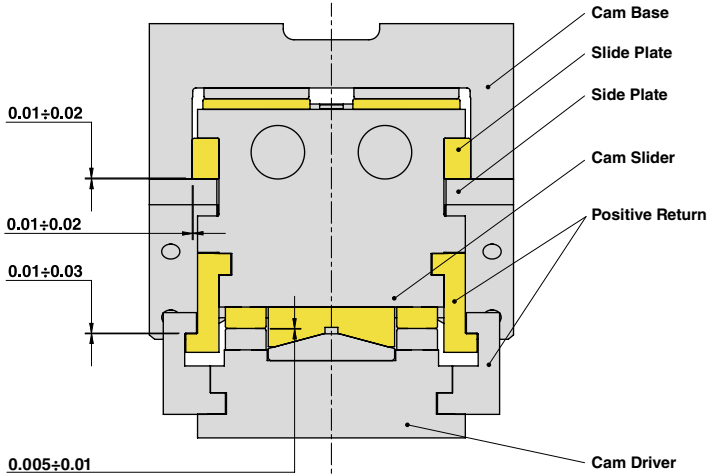

PART LIST

Particular number	Description	Material	Quantity
1	Cam Slider	GG-30	1
2	Cam Base	GG-30	1
3	Cam Driver	GG-30	1
4	Male "V" Driver	CK45	1
5	Female "V" Driver	CuZn25Al5 + Graphite - HB > 190	1
6	Side Plate	CK45	2
7	Slide Plate L	CuZn25Al5 + Graphite - HB > 190	1
8	Wear Plate	CuZn25Al5 + Graphite - HB > 190	2
9	Safety Pin	CK45	1
10	Stopper Plate	St 52	1
11	Spring Guide Pin	CK45	2
12	Slide Plate R	CuZn25Al5 + Graphite - HB > 190	1
13	Positive Return R	CuZn25Al5 - HB > 190	1
14	Positive Return L	CuZn25Al5 - HB > 190	1
15	Positive Return R	42CrMo4 Nitrided	1
16	Positive Return L	42CrMo4 Nitrided	1
17	Key	CK45	6
18	Shaft	CK45	1
19	Roller Bracket	CK45	1
20	Accelerator	CK45	1
21	Wear Plate	CK45	2
22	Wear Plate	CK45	4
23	Wear Plate	CuZn25Al5 + Graphite - HB > 190	2
24	Roller	NATR15PP	1
25G	Gas Spring - Return Type G	-	2
25S	Spring - Return Type S	-	2
26	Cam Driver Fixing Screws M16x70 DIN 912	-	4
27	Cam Base Fixing Screws M16x70 DIN 912	-	4
28	Gas Spring Spacer	CK45	2
29	Elastomer Cap	Elastomer 92SH	4



AERIAL CAM UNIT - OBEN HÄNGENDER SCHIEBER - UNITÀ A CAMME SOSPESA

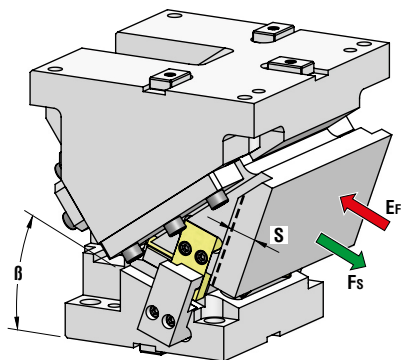

OMCR CODE	Work Angle β	Stroke (mm) S	Max Work Force with shoulder (kN) Fs	Extraction Force (kN) Ef	
				Spring	Gas Spring
CHD300.00	0°	28,68	645	4,58	14,30
CHD300.05	5°	32,26	645	4,58	14,30
CHD300.10	10°	35,90	645	4,58	14,30
CHD300.15	15°	39,65	645	4,58	14,30
CHD300.20	20°	43,59	645	4,58	14,30
CHD300.25	25°	47,78	645	4,58	14,30
CHD300.30	30°	52,33	645	4,58	14,30
CHD300.35	35°	57,36	645	4,58	14,30
CHD300.40	40°	63,05	645	4,58	14,30
CHD300.45	45°	69,64	645	4,58	14,30
CHD300.50	50°	77,49	645	4,58	14,30
CHD300.55	55°	87,17	645	4,58	14,30
CHD300.60	60°	99,62	645	4,58	14,30
CHD300.65	65°	116,51	645	4,58	14,30

*Return Type: G = Gas Spring / S = Spring



Art.	Work Angle = 5°	Return Type*
CHD300	05	G

OMCR CODE	Work Angle β	Overall Dimensions (mm)				
		A	B	C	D	E
CHD300.00	0°	325	90	80	310	25
CHD300.05	5°	323,19	93,41	60	290	25
CHD300.10	10°	326,01	98,40	45	275	25
CHD300.15	15°	333,33	104,92	35	265	20
CHD300.20	20°	340,02	112,93	25	255	15
CHD300.25	25°	345,94	122,35	15	245	10
CHD300.30	30°	345,98	133,14	0	230	0
CHD300.35	35°	345,03	160,19	-15	215	0
CHD300.40	40°	337,97	173,42	-35	195	0
CHD300.45	45°	334,71	187,72	-50	180	0
CHD300.50	50°	325,15	202,99	-70	160	0
CHD300.55	55°	314,23	219,12	-90	140	0
CHD300.60	60°	306,86	235,98	-105	125	0
CHD300.65	65°	298	253,44	-120	110	0



AERIAL CAM UNIT - OBEN HÄNGENDER SCHIEBER - UNITÀ A CAMME SOSPESA

X VIEW

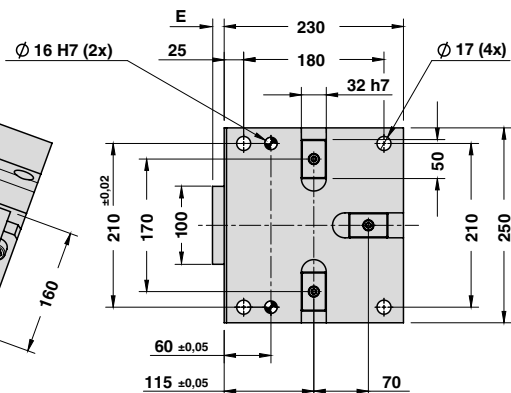
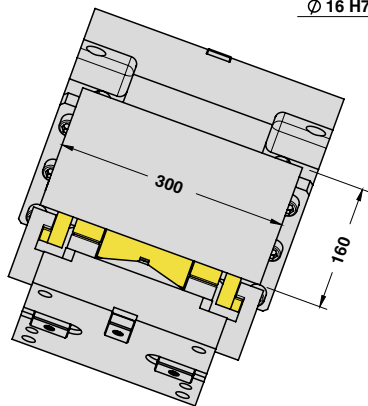

CAM DIAGRAM

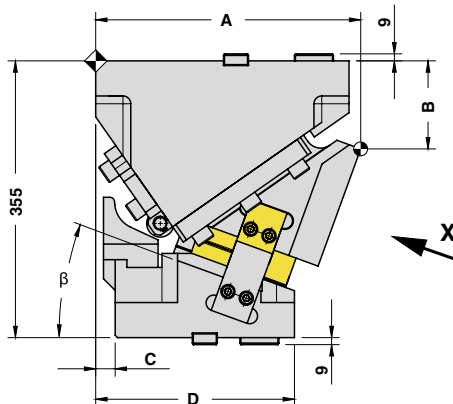
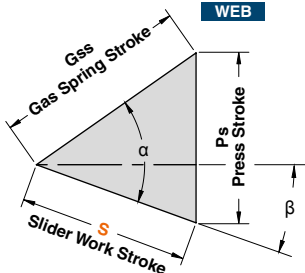

Work Angle	Inner Angle	Slider Work Stroke (mm)	Press Stroke (mm)	Gas Spring Stroke (mm)
β	α	S	Ps	Gss
0°	55°	28,68	40,96	50
5°	55°	32,26	41,11	50
10°	55°	35,90	41,59	50
15°	55°	39,65	42,40	50
20°	55°	43,59	43,59	50
25°	55°	47,78	45,19	50
30°	55°	52,33	47,29	50
35°	55°	57,36	50,00	50
40°	55°	63,05	53,47	50
45°	55°	69,64	57,92	50
50°	55°	77,49	63,72	50
55°	55°	87,17	71,41	50
60°	55°	99,62	81,92	50
65°	55°	116,51	96,91	50

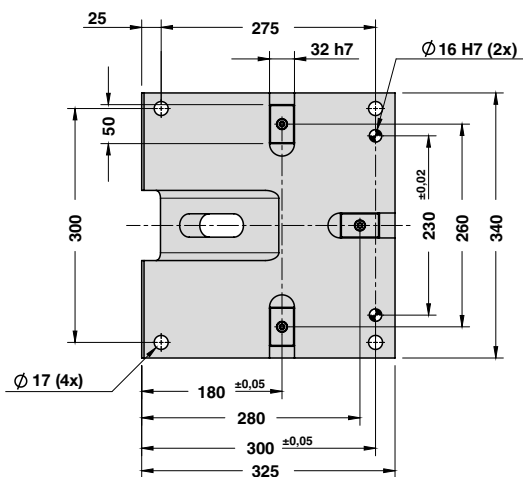

Cam Units CHD



AERIAL CAM UNIT - OBEN HÄNGENDER SCHIEBER - UNITÀ A CAMME SOSPESA

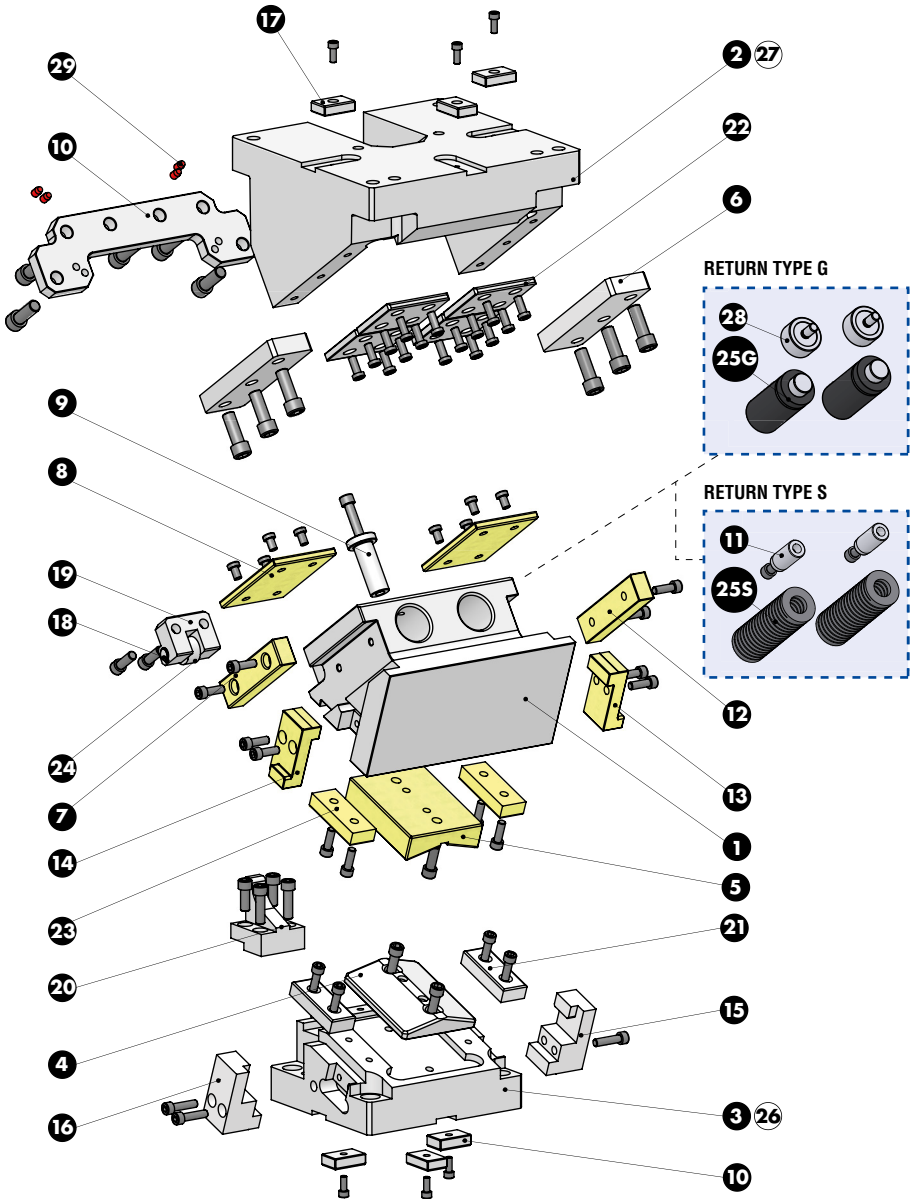



AERIAL CAM UNIT - OBEN HÄNGENDER SCHIEBER - UNITÀ A CAMME SOSPESA

SLIDER STRUCTURE, POSITIVE RETURN STRUCTURE AND CLEARANCES

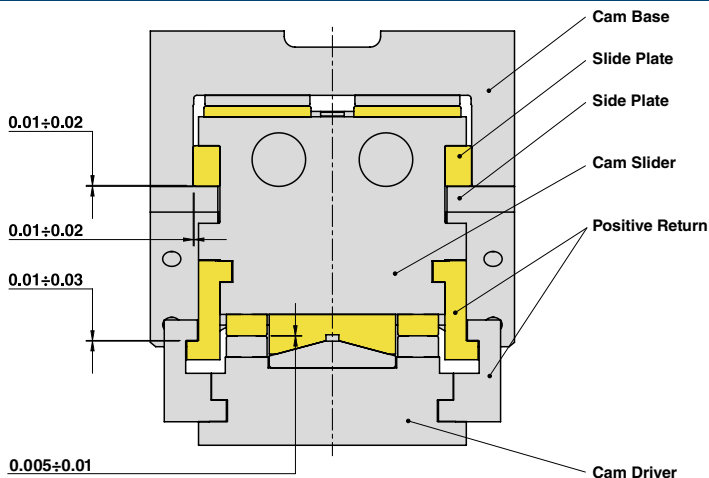

PART LIST

Particular number	Description	Material	Quantity
1	Cam Slider	GG-30	1
2	Cam Base	GG-30	1
3	Cam Driver	GG-30	1
4	Male "V" Driver	CK45	1
5	Female "V" Driver	CuZn25Al5 + Graphite - HB > 190	1
6	Slide Plate	CK45	2
7	Slide Plate L	CuZn25Al5 + Graphite - HB > 190	1
8	Wear Plate	CuZn25Al5 + Graphite - HB > 190	2
9	Safety Pin	CK45	1
10	Stopper Plate	St 52	1
11	Spring Guide Pin	CK45	2
12	Slide Plate R	CuZn25Al5 + Graphite - HB > 190	1
13	Positive Return R	CuZn25Al5 - HB > 190	1
14	Positive Return L	CuZn25Al5 - HB > 190	1
15	Positive Return R	42CrMo4 Nitrided	1
16	Positive Return L	42CrMo4 Nitrided	1
17	Key	CK45	6
18	Shaft	CK45	1
19	Roller Bracket	CK45	1
20	Accelerator	CK45	1
21	Wear Plate	CK45	2
22	Wear Plate	CK45	4
23	Wear Plate	CuZn25Al5 + Graphite - HB > 190	2
24	Roller	NATR15PP	1
25G	Gas Spring - Return Type G	-	2
25S	Spring - Return Type S	-	2
26	Cam Driver Fixing Screws M16x70 DIN 912	-	4
27	Cam Base Fixing Screws M16x70 DIN 912	-	4
28	Gas Spring Spacer	CK45	2
29	Elastomer Cap	Elastomer 92SH	4

Cam Units CHD